



MILLER ENVIRONMENTAL

# Secondary Containment Liner System

With leak detection inspection pipe and optional alarm (#METLBS30M)

Miller Environmental, the nation's leader in Septic Tank Liners and Breakout Barrier Liners, has developed a solution for providing secondary containment of industrial waste holding tanks with leak detection. This system is suitable for safely retaining wastes from beauty shops, floor drains and many other facilities listed with a Standard Industrial Classification (SIC) code that are required to store waste streams from industrial processes in holding tanks for offsite disposal. The Miller Environmental Interior Liner System allows you to meet environmental code requirements for secondary containment with an inspection and optional alarm standpipe and a leak detection system placed between the tank and the liner. The inspection and alarm standpipes are brought to grade and capped in a street box or other suitable access box.

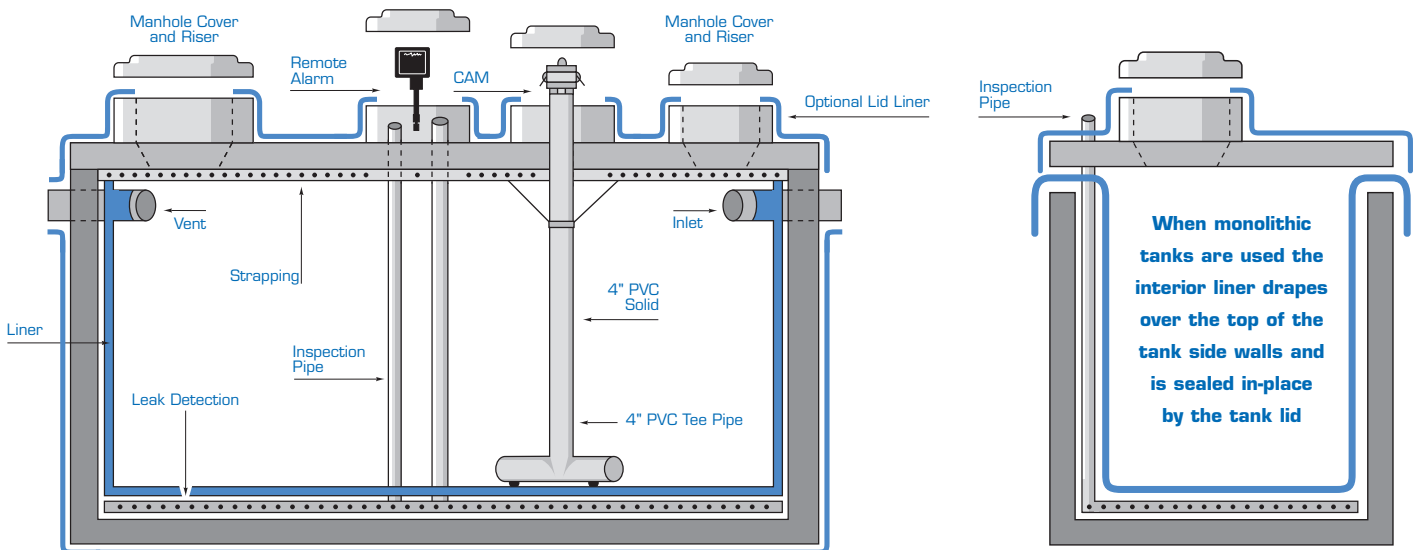

The SCLS is designed to provide interior containment of industrial wastes within precast concrete tanks. It is important to note that all precast concrete tanks used for this application must be certified as water-tight by field testing. Once the precast tank is set in place and certified as water-tight the Miller Environmental leak detection system is installed within the tank as shown above. The inspection pipe and alarm standpipes slip through holes in the top of the tank that are either cored onsite or provided

by the pre-caster. Then the liner is installed within the precast tank over the leak detection piping and fastened to the top of the interior wall of the precast concrete tank with boots around the inlet and vent pipe. A multiple-piece type tank should be lined on the outside as well, especially in high ground water applications.

Miller Environmental also recommends a lid liner with manhole riser boots for these installations. This completely encloses the top of the tank protecting the secondary containment system from surface water runoff.

Installation is quick and simple and installation directions are included with each SCLS kit, but for those who prefer Miller Environmental offers SCLS installation services.

The optional pump-out standpipe shown can be provided to make pump-outs quick and easy. This device allows the pumper to quickly connect the pump-out hose to a watertight, clip-on connection specifically design for this application.

To obtain a free quote of the Miller Environmental SCLS for specific projects please fax, mail or e-mail cut sheets of the exact industrial waste holding tank associated with the installation. Exact location and dimensions of pipe penetrations and manhole risers are essential to ensure proper fabrication of the liner(s).

**Call today 508.378.3800**

Fax 508.378.2411

jeffmiller@millerenvironmentalinc.com

Visit us online at [www.millerenvironmentalinc.com](http://www.millerenvironmentalinc.com)  
for more information, drawings and technical specs



Post Office Box 334  
608 Spring Street  
East Bridgewater, MA  
02333

MILLER ENVIRONMENTAL